

FR

EN

DE

NL

IT

ES

PT

EL

AR

FA

ZH

MS

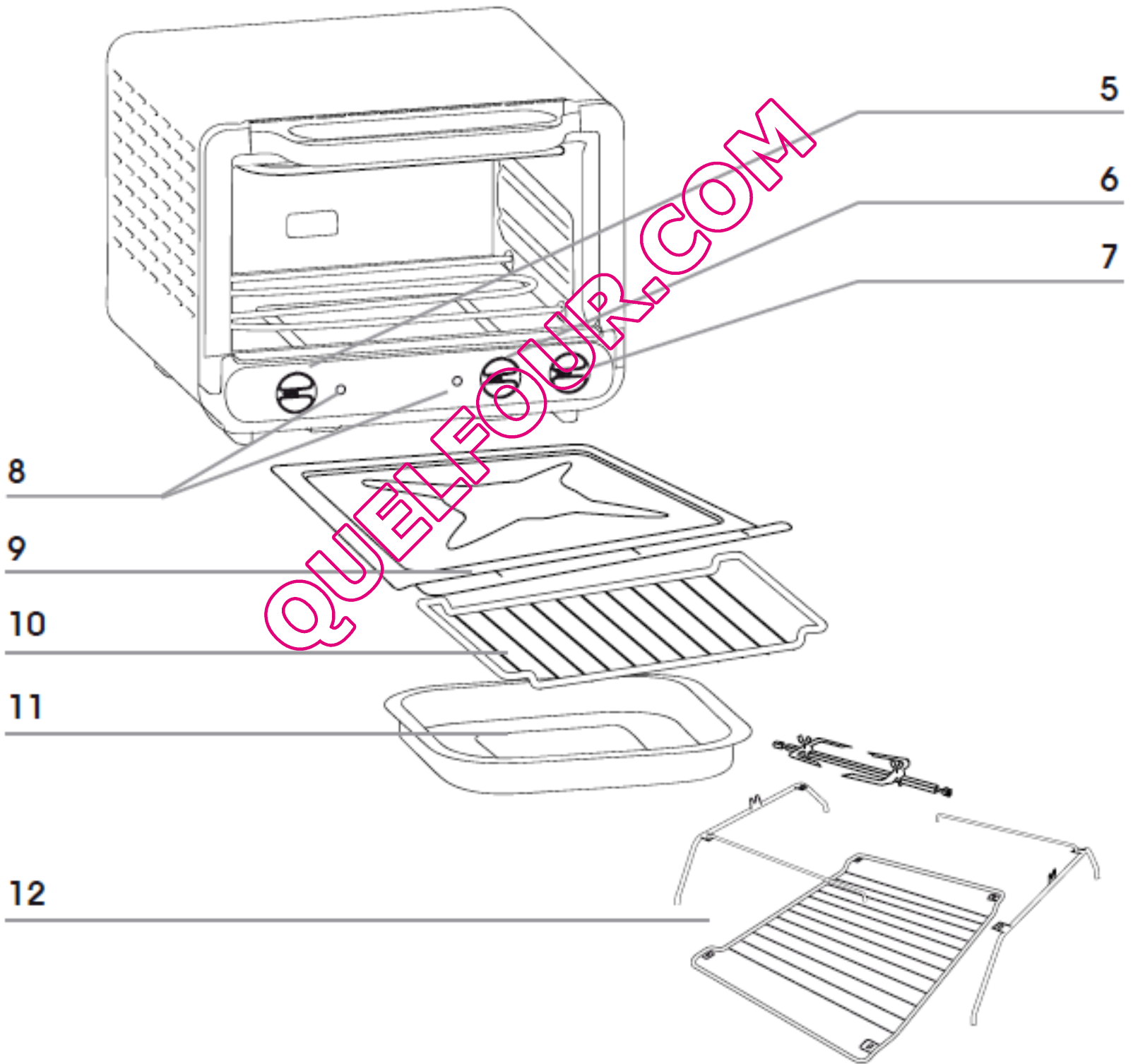
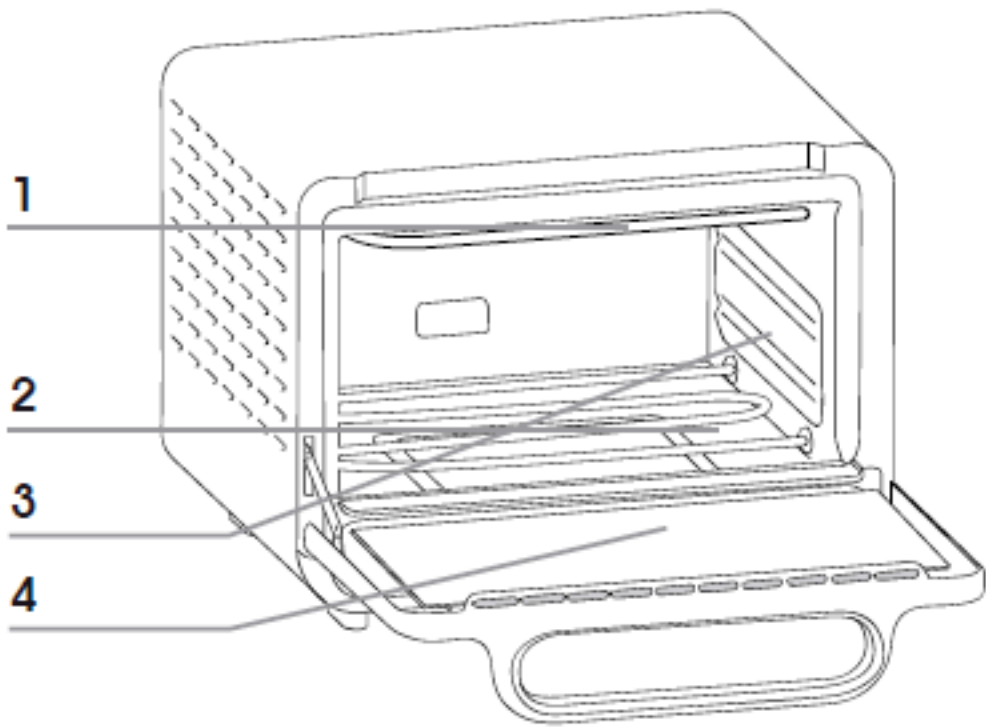

DESCRIPTION

1. Résistance supérieure
2. Résistance inférieure
3. Parois non stick
4. Porte double parois
5. Bouton des fonctions
6. Bouton de réglage température
7. Bouton de minuterie
8. Voyants de fonctionnement
9. Sole ramasse miettes
10. Grille réversible
11. Plat non adhésif
12. Kit tournebroche (1 grille, 2 fourches, 2 supports broche, 1 tige, 1 plat)

DESCRIPTION

1. Top heating element
2. Bottom heating element
3. Non-stick walls
4. Double-wall door
5. Function buttons
6. Temperature control button
7. Timer button
8. Power indicator lights
9. Crumb tray
10. Reversible shelf
11. Non-stick oven tray
12. Rotisserie kit (1 grill, 2 forks, 2 meat holders, 1 spit rod, 1 plate)

BESCHREIBUNG

1. Oberes Heizelement
2. Unteres Heizelement
3. Antihaftbeschichtete Wände
4. Doppelwandige Tür
5. Funktionsknöpfe
6. Temperaturregler
7. Timer-Knopf
8. Betriebsleuchten
9. Krümelblech
10. Umkehrbarer Rost
11. Antihaftbeschichtete Backform
12. Drehspieß-Set (1 Rost, 2 Gabeln, 2 Spießhalterungen, 1 Spieß, 1 Schale)

BESCHRIJVING

1. Bovenste verwarmingselement
2. Onderste verwarmingselement
3. Anti-aanbakwanden
4. Dubbelwandige deur
5. Functieknoppen
6. Temperatuurregelknop
7. Timerknop
8. Aan/uit-controlelampjes
9. Kruimellade
10. Omkeerbaar rooster
11. Anti-aanbakovenschaal
12. Draaispiset (1 rooster, 2 vorken, 2 spithouders, 1 stang, 1 schaal)

DESCRIPCIÓN

1. Resistencia superior
2. Resistencia inferior
3. Paredes antiadherentes
4. Puerta de doble cristal
5. Botones de funciones
6. Botón de ajuste de temperatura
7. Botón de temporizador
8. Pilotos de funcionamiento
9. Bandeja recogemigas
10. Rejilla reversible
11. Fuente antiadherente
12. Kit de asador (1 rejilla, 2 tenedores, 2 soportes para brocheta, 1 varilla, 1 fuente)

DESCRIPTION

1. Resistência superior
2. Resistência inferior
3. Paredes antiaderentes
4. Porta de parede dupla
5. Botões das funções
6. Botão de regulação da temperatura
7. Botão temporizador
8. Indicadores de funcionamento
9. Bandeja para migalhas
10. Grelha reversível
11. Prato não aderente
12. Kit espeto rotativo (1 grelha, 2 forquilhas, 2 suportes para espeto, 1 haste, 1 prato)

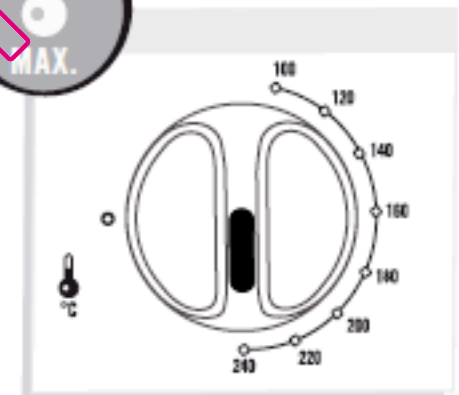
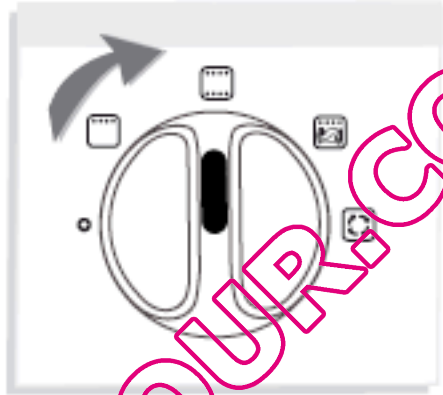
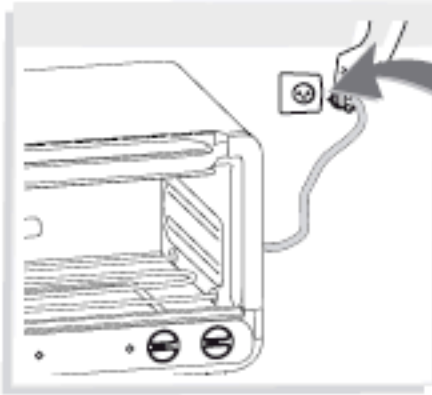
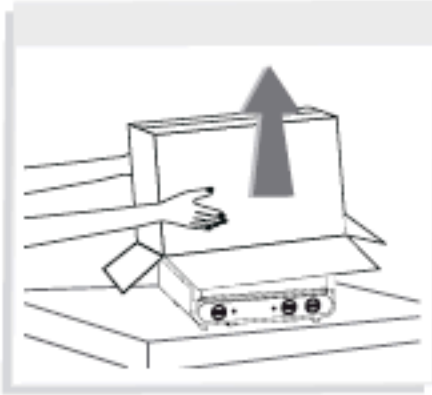
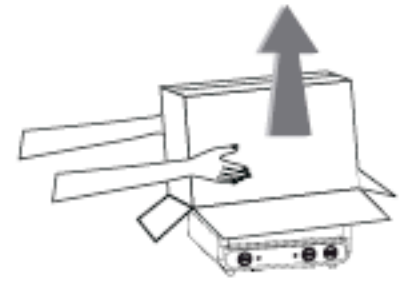

20 min

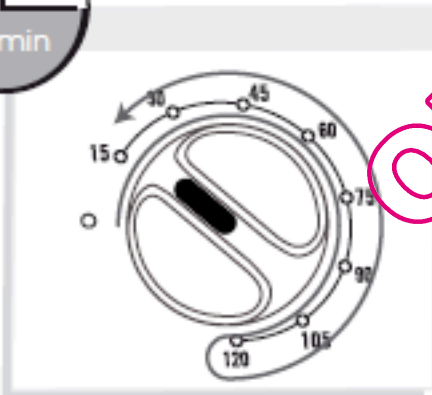

0 min

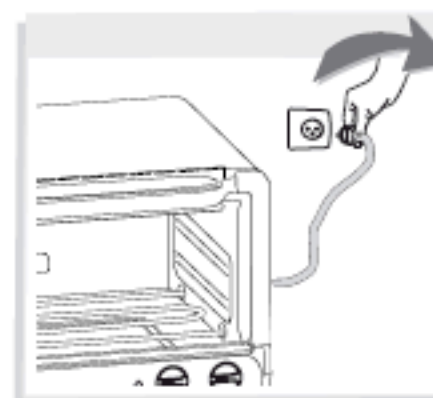
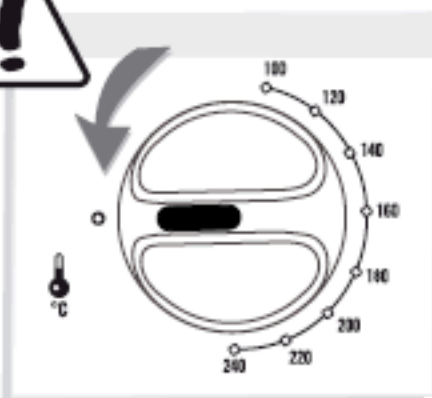

>20 min



QUELFORUM.COM

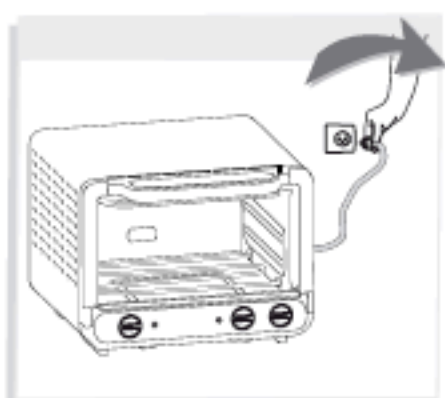
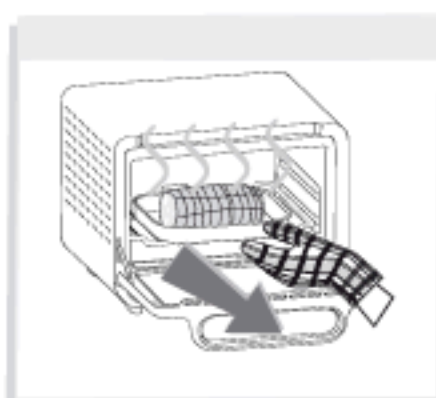
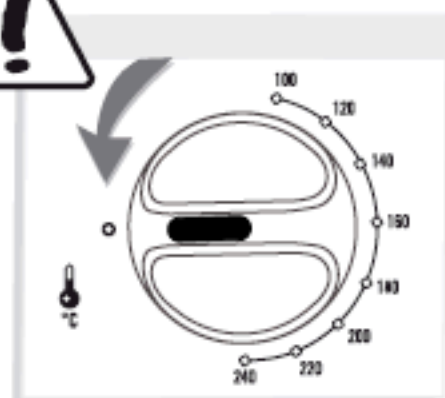
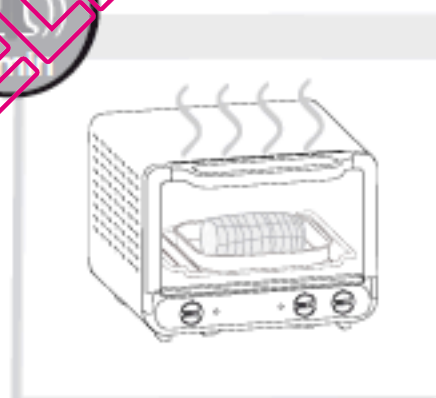
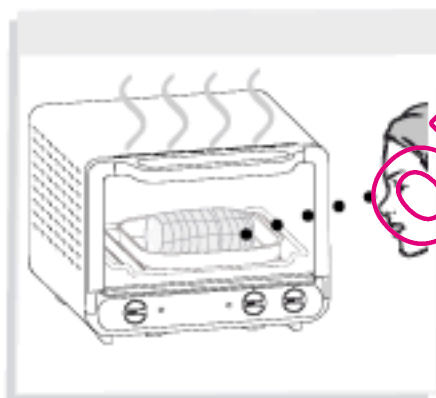
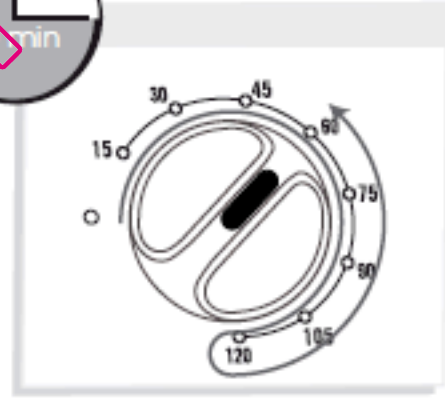
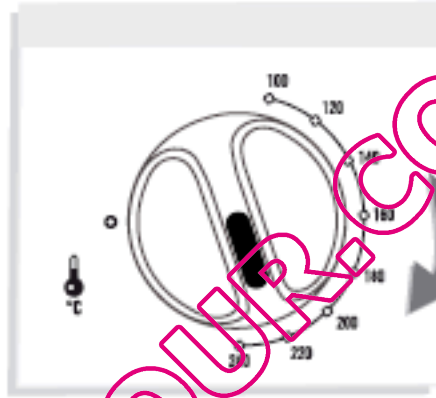
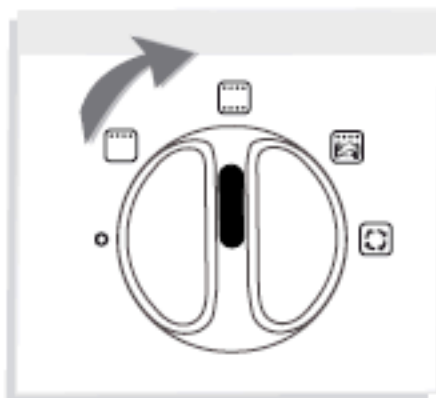
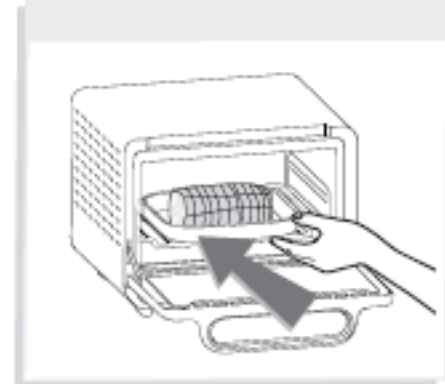
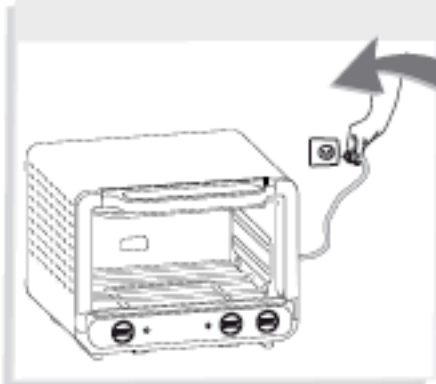

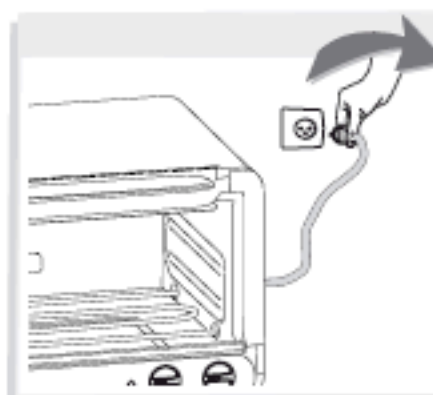
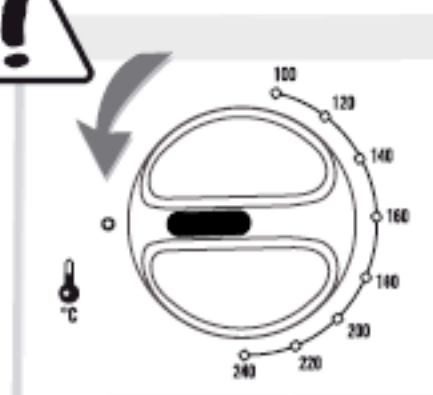
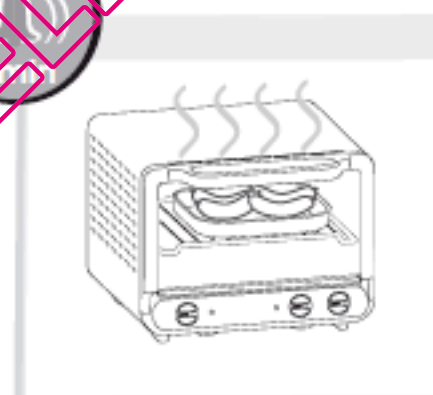
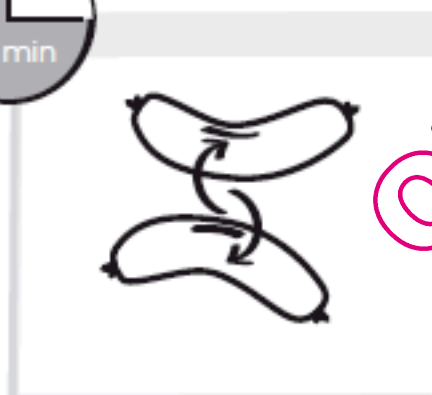
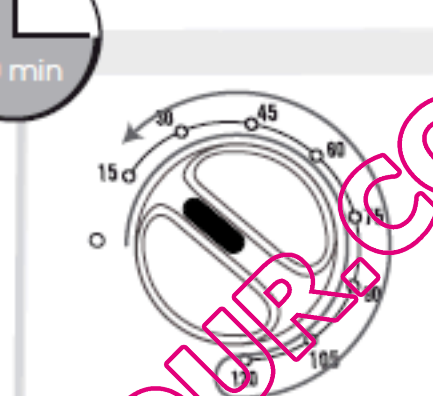
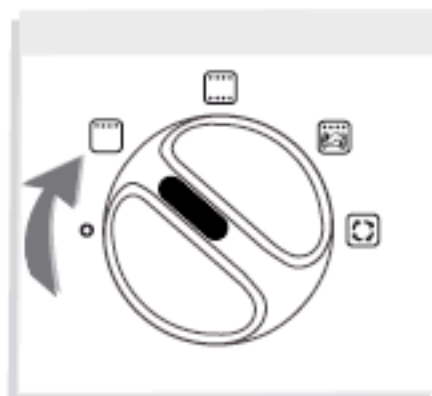
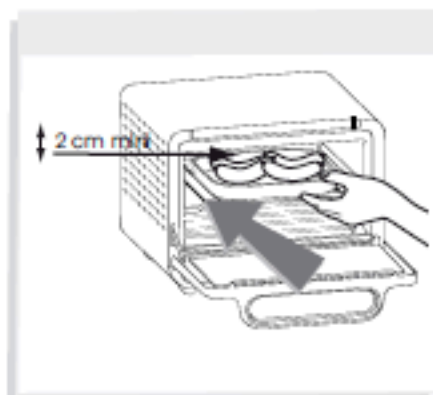
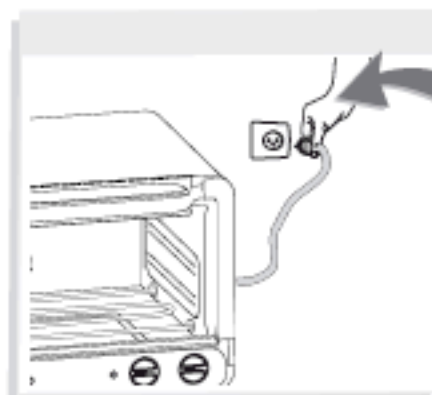

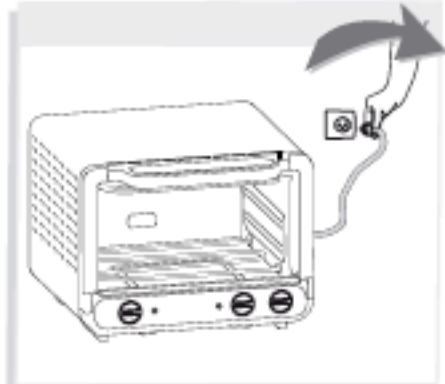
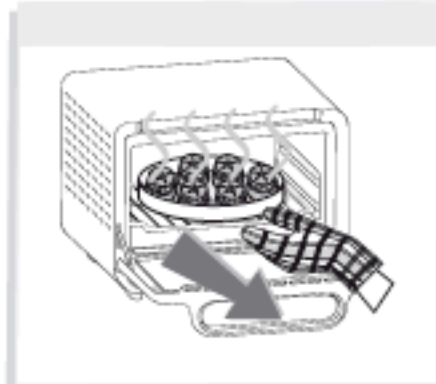
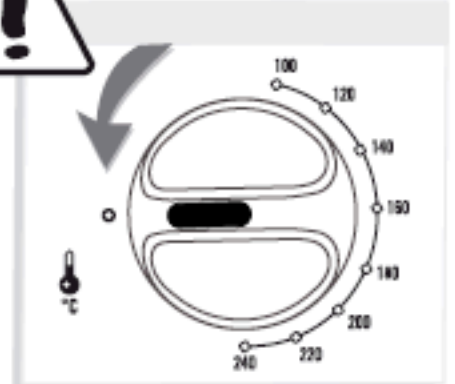
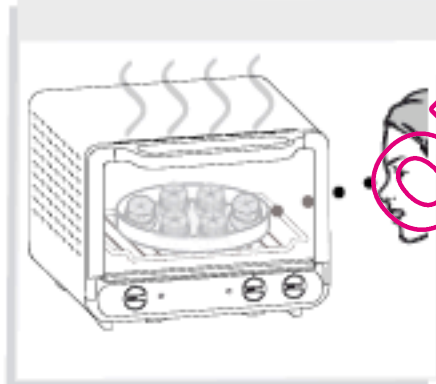
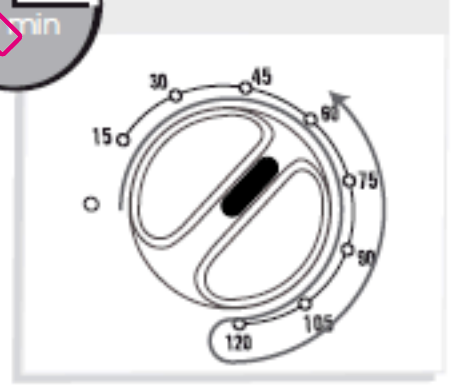
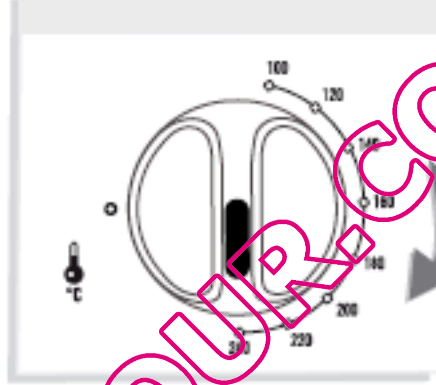
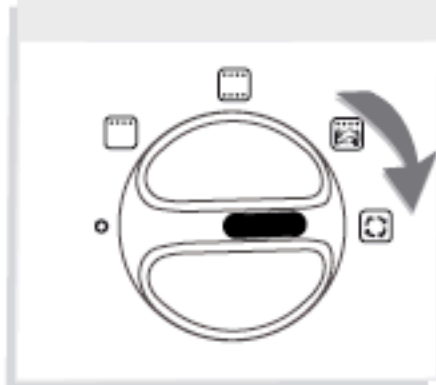
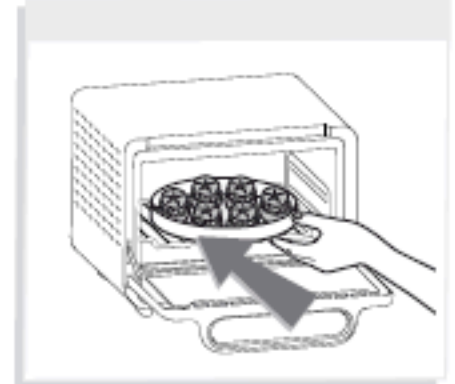
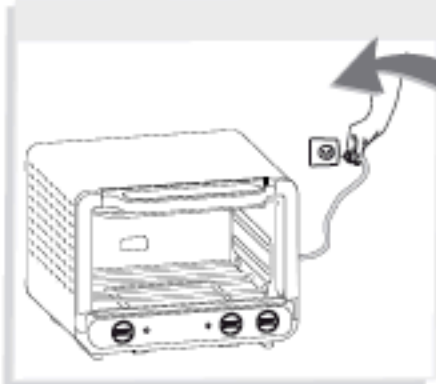

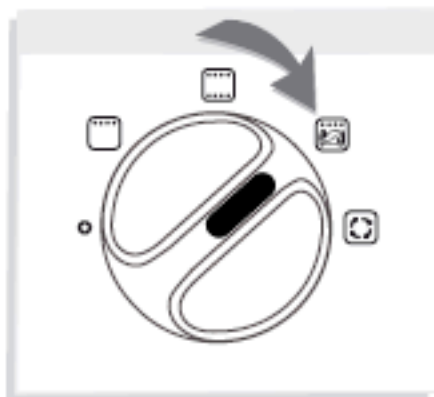
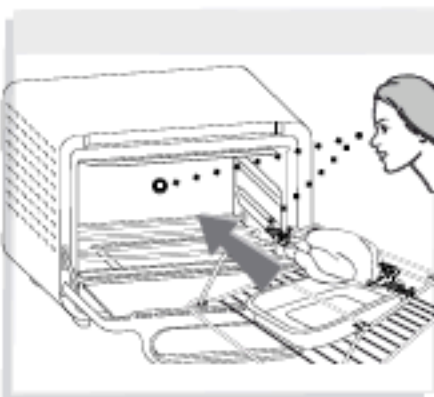
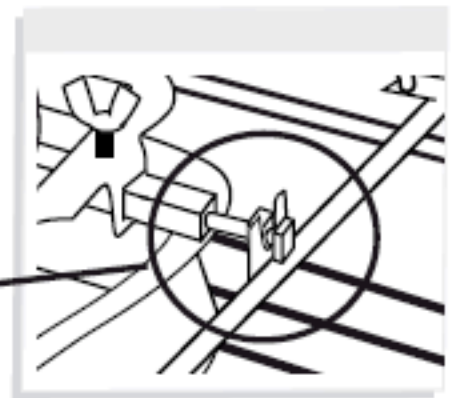
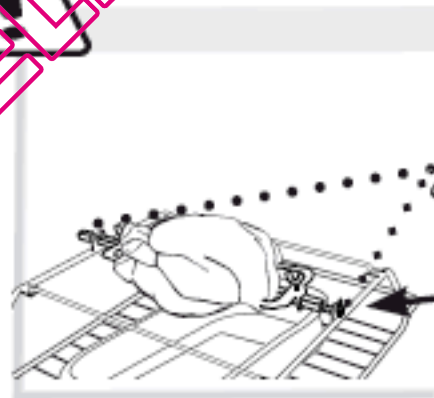
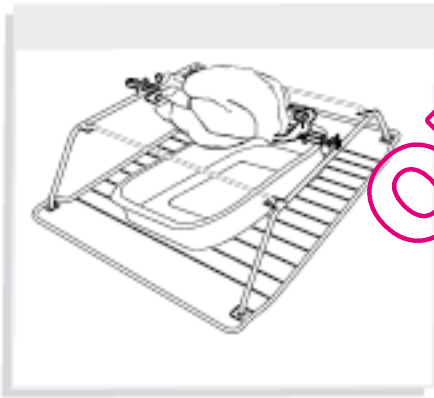
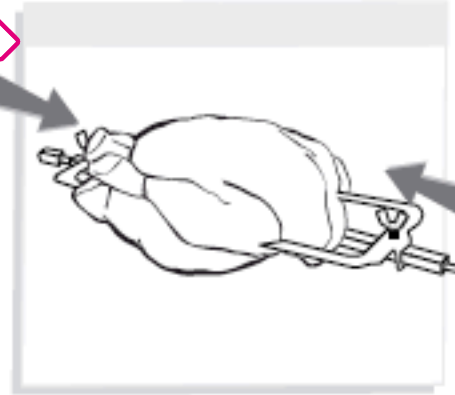
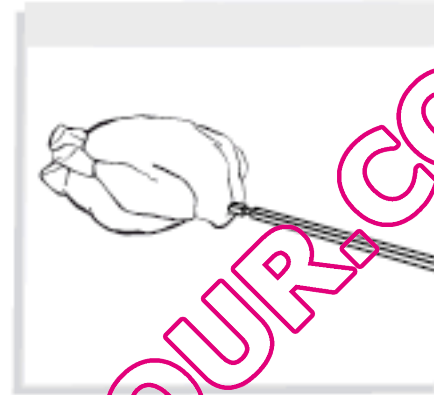
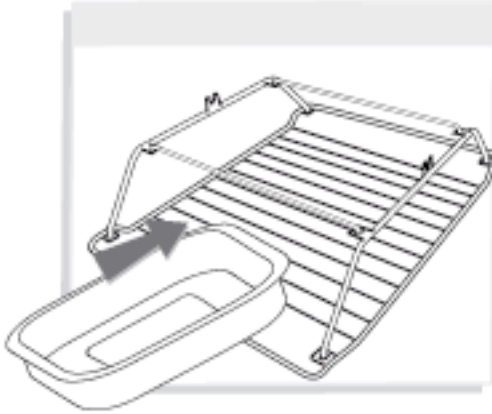
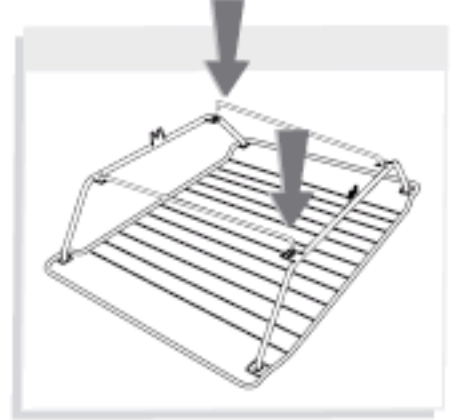
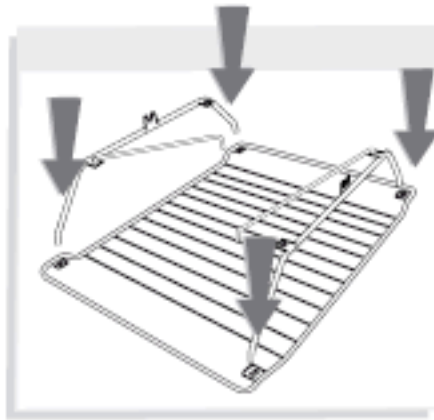

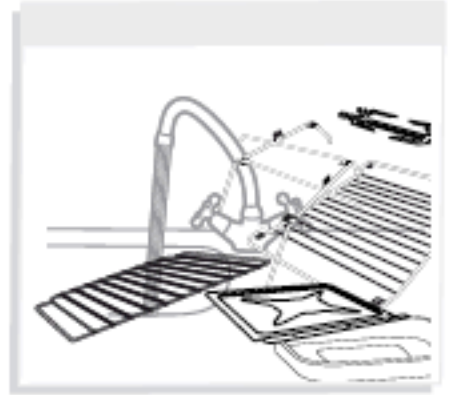

QUELFOR.COM



				Préchauffage Preheat	
		4	240	10 min	20 min
		3	220	-	70 min
		-	-	-	80 min
		4	240	10 min	20 min
		5	240	-	80 min
		8	-	10 min	16 + 6 min
		8	-	5 min	12 + 8 min
		4	240	-	28 min
		2	240	5 min	55 min
		3	220	10 min	25 min
		4	240	-	30 min
		3	180	10 min	50 min
		4	180	10 min	25 min

